

Piston Check Valves

Cast Steel

Sizes 1" - 24"

Class 150 - 2500



Design and Manufacturing Standards

Basic Design	API 6D
Shell Wall Thickness	ANSI/ASME B16.34
Face to Face Dimension	As stated
Flange End Dimension	ANSI/ASME B16.5
Inspection & Testing	API 6D



Southern California Valve

1" - 24"

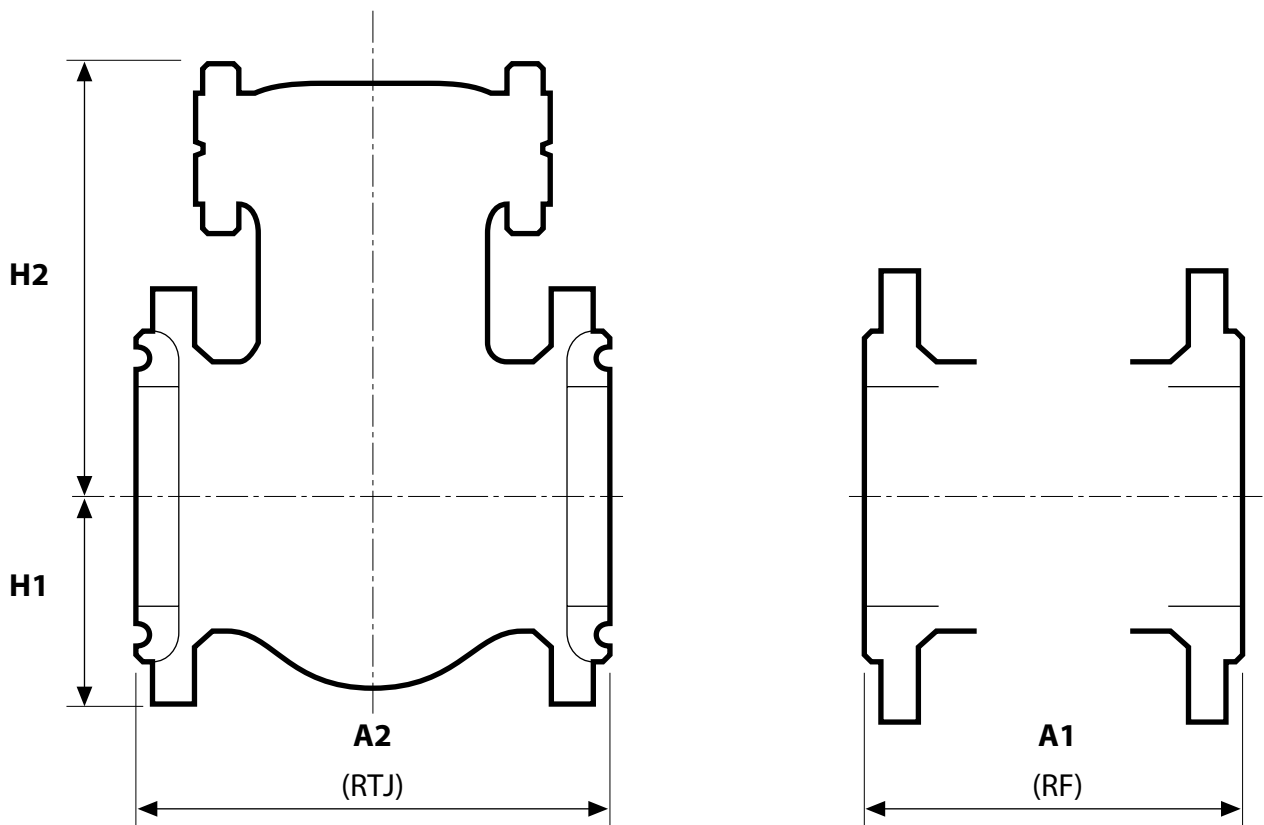
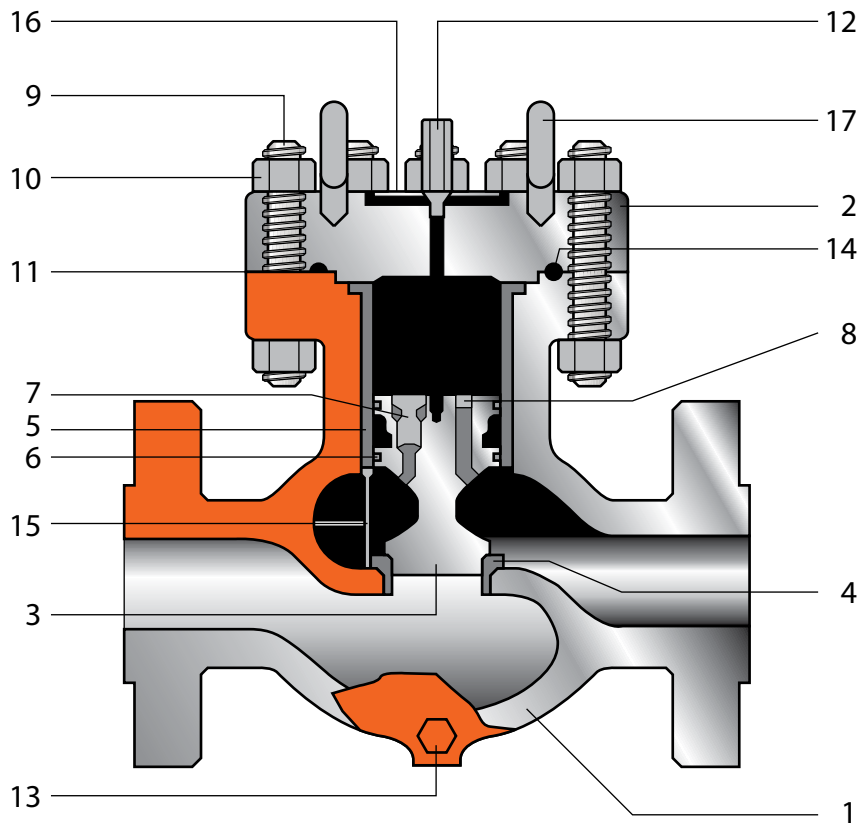

BILL OF MATERIAL

NO	NAME OF PART	MATERIAL
1	BODY	CAST CARBON STEEL, ASTM A-216 WCC
		CAST ALLOY STEEL, ASTM A-487-N
2	COVER	FORGED STEEL, ASTM A-105-GR. 1
		FORGED STEEL, ASTM A-105-GR. 2
3	PISTON	WC6+STL6
4	SEAT	ASTM A105+STL6
5	LINER	CS+ENP
6	PISTON RINGS	CHROME MOLY
*7	INLINE BALL CHECK	STAINLESS STEEL
*8	ORIFICE PLUG	STAINLESS STEEL
9	STUDS	B7M
10	HEX NUTS	ASTM A-194-GR 2HM
11	BODY - COVER - LINER GASKET	SPIRAL WOUND+GRAPHITE/ RING JOINT
*12	BLEEDER PLUG	CARBON STEEL
13	DRAIN PLUG	CARBON STEEL
14	SEAT LOCKING PIN	STAINLESS STEEL
15	IDENTIFICATION PLATE	CAST ALUMINUM
*16	LIFTING EYE BOLTS	STEEL
* ALL PISTON CHECK VALVES 2" THRU 6", IN ALL PRESSURES, COMES STANDARD WITH A 304SS SPRING INSTALLED.		
NOTE: AVAILABLE IN OTHER MATERIALS UPON REQUEST.		

CLASS 150 - CAST STEEL PISTON CHECK VALVES

DIMENSIONS & WEIGHTS

SIZE	nps	1	1.5	2	3	4	6	8	10	12	14	16	18	20	24
	dn	25	40	50	80	100	150	200	250	300	350	400	450	500	600
A1 (RF)	in	/	/	8.0	9.49	11.5	15.98	/	24.49	27.48	/	/	/	/	/
	mm	/	/	203	241	292	406	/	622	698	/	/	/	/	/
A2 (RTJ)	in	/	/	/	/	/	/	/	/	/	/	/	/	/	/
	mm	/	/	/	/	/	/	/	/	/	/	/	/	/	/
H1	in	/	/	/	/	/	/	/	/	/	/	/	/	/	/
	mm	/	/	/	/	/	/	/	/	/	/	/	/	/	/
H2	in	/	/	7.0	8.35	10.23	14.56	/	22.48	25.51	/	/	/	/	/
	mm	/	/	178	212	260	370	/	571	648	/	/	/	/	/
WGT	lb	/	/	/	/	/	/	/	/	/	/	/	/	/	/
(RF)	kg	/	/	/	/	/	/	/	/	/	/	/	/	/	/

CLASS 300 - CAST STEEL PISTON CHECK VALVES

DIMENSIONS & WEIGHTS

SIZE	nps	1	1.5	2	3	4	6	8	10	12	14	16
	dn	25	40	50	80	100	150	200	250	300	350	400
A1 (RF)	in	7.5	11.25	10.25	14.75	17.625	19.375	22.5	29.625	32	35.25	39.125
	mm	191	286	260	375	448	492	572	752	813	895	994
A2 (RTJ)	in	/	/	/	/	/	/	/	/	/	/	/
	mm	/	/	/	/	/	/	/	/	/	/	/
H1	in	2.25	3.25	3.25	4.875	5	6.75	9.25	11.75	13.25	14.875	17
	mm	57	83	83	124	127	171	235	298	337	378	432
H2	in	5.875	8.5	8.5	10.25	12.5	17.5	20.125	23.75	24.375	27.25	30.125
	mm	149	216	216	260	318	445	511	603	619	692	765
WGT	lb	45	78	80	155	250	415	750	1300	1660	2500	3100
(RF)	kg	20	35	36	70	114	187	341	591	755	1136	1409

CLASS 600 - CAST STEEL PISTON CHECK VALVES

DIMENSIONS & WEIGHTS

SIZE	nps	1	1.5	2	3	4	6	8	10	12	14	16	18	20	24
	dn	25	40	50	80	100	150	200	250	300	350	400	450	500	600
A1 (RF)	in	8	11.25	11	14.75	18.5	20.75	24	30.875	33.625	37	41.25	46	55.5	60
	mm	203	286	279	375	470	527	610	784	854	940	1048	1168	1410	1524
A2 (RTJ)	in	8.125	11.25	11.375	14.875	18.625	20.875	24.125	30.875	33.75	37.125	41.375	46.125	55.75	60.125
	mm	206	286	283	378	461	530	613	787	857	943	1051	1172	1413	1527
H1	in	2.5	3.25	3.25	5.25	5.375	7	9.25	11.75	13.125	14.875	17	19.25	20.875	22.125
	mm	64	83	83	133	137	178	235	298	333	378	432	489	530	561
H2	in	5.875	8.5	8.5	10.25	12.125	18	20.25	24.25	25.125	28.125	31.25	32.875	35.25	38.78
	mm	149	216	216	260	308	457	514	616	638	714	794	835	895	985
WGT (RF)	lb	50	80	85	175	290	550	810	1650	2450	2900	3700	4600	7900	10200
	kg	23	36	39	80	132	250	368	750	1114	1318	1682	2091	3591	4636

CLASS 900 - CAST STEEL PISTON CHECK VALVES

DIMENSIONS & WEIGHTS

SIZE	nps	1	1.5	2	3	4	6	8	10	12	14	16	18	20	24
	dn	25	40	50	80	100	150	200	250	300	350	400	450	500	600
A1 (RF)	in	11.25	13.625	13.625	14.875	19.375	21.875	24.875	31.375	33.875	/	/	/	/	/
	mm	203	346	346	378	492	556	632	797	860	/	/	/	/	/
A2 (RTJ)	in	11.375	13.75	13.75	15	19.5	22	25	31.5	33.125	/	/	/	/	/
	mm	289	349	349	381	495	559	635	800	857	/	/	/	/	/
H1	in	2.5	3.25	3.25	5.25	5.375	7	9.25	11.75	13.125	/	/	/	/	/
	mm	64	83	83	133	137	178	235	298	333	/	/	/	/	/
H2	in	5.875	8.5	8.5	10.25	12.125	18	20.25	24.25	25.125	/	/	/	/	/
	mm	149	216	216	260	308	457	514	616	638	/	/	/	/	/
WGT (RF)	lb	50	80	85	175	290	550	810	1650	2450	/	/	/	/	/
	kg	23	36	39	80	132	250	368	750	1114	/	/	/	/	/

CLASS 1500 - CAST STEEL PISTON CHECK VALVES

DIMENSIONS & WEIGHTS

SIZE	nps	1	1.5	2	3	4	6	8	10	12	14	16	18
	dn	25	40	50	80	100	150	200	250	300	350	400	450
A1 (RF)	in	11.25	13.625	13.625	17.25	20.25	24	32.375	34.375	41	50.5	/	/
	mm	286	346	346	438	514	610	822	873	1041	1283	/	/
A2 (RTJ)	in	11.25	13.75	13.75	17.325	20.375	24.25	32.75	35	41.675	51.25	55.39	61.38
	mm	286	349	349	440	518	616	832	889	1059	1302	1407	1559
H1	in	2.5	3.25	3.25	5.25	5.375	7	9.25	11.75	13.125	14.875	/	/
	mm	64	83	83	133	137	178	235	298	333	378	/	/
H2	in	5.875	8.5	8.5	10.25	12.125	18	20.25	24.25	25.125	28.125	33.62	36.42
	mm	149	216	216	260	308	457	514	616	638	714	854	925
WGT (RF)	lb	50	80	85	175	290	550	810	1650	2450	2900	/	/
	kg	23	36	39	80	132	250	368	750	1114	1318	/	/

CLASS 2500 - CAST STEEL PISTON CHECK VALVES

DIMENSIONS & WEIGHTS

SIZE	nps	1	1.5	2	3	4	6	8	10
	dn	25	40	50	80	100	150	200	250
A1 (RF)	in	12.25	14.875	14.875	20.25	23.125	32	37.375	40.375
	mm	311	378	378	512	587	813	949	1026
A2 (RTJ)	in	12.25	15	15	20.5	23.5	32.5	38	41.25
	mm	311	381	381	521	597	826	965	1022
H1	in	2.5	3.25	3.25	5.25	5.375	7	9.25	11.75
	mm	64	83	83	133	137	178	235	298
H2	in	5.875	8.5	8.5	10.25	12.125	18	20.25	24.25
	mm	149	216	216	260	308	457	514	616
WGT (RF)	lb	50	80	85	175	290	550	810	1650
	kg	23	36	39	80	132	250	368	750